

DOG BONE COMPACT COMBINATION LAMPS



Voltage Range: 12V

Warranty: 2 years

Ingress Protection: IP67

Approval: ECE & EMC ✓

- Unique 'dog-bone' shape
- Exclusive LED Autolamps design
- Horizontal or vertical mounting
- Shock, water & dust proof
- Low current draw

CLICK & STICK MOUNTING SYSTEM

See p. iv-v for more information



NEW

STOP / TAIL / INDICATOR / REFLECTOR

DB 12V

DB2 12V (Twin Pack)

Current Draw (13.8V / 28V):

Stop: 0.07A, Tail: 0.01A, Indicator: 0.06A

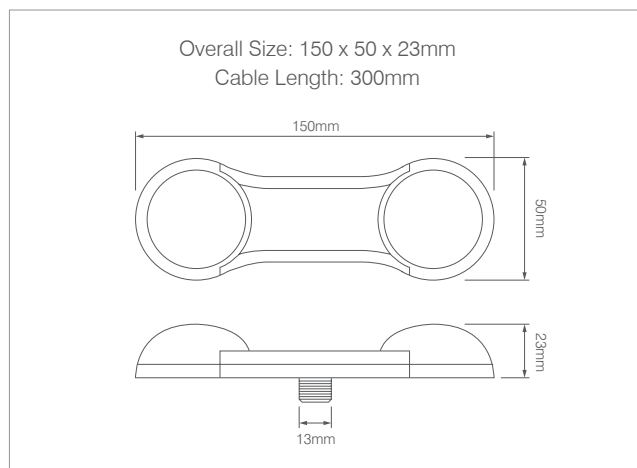

**APPROVED FOR VERTICAL
OR HORIZONTAL MOUNTING**

